

SP

*Series*

*40 pound*

*60 pound*

*100 pound*

*155 pound*

*185 pound*



Washer Extractor



# SP

## Series – SOFTMOUNT

**The Image SP Series - Softmount High-Speed Professional Washer-Extractors for Small to Medium Size Demanding On-Premise Laundry Applications, including Health Care, Hospitality and Drycleaners/Wet Cleaning.**

### **The SP Series - Outstanding reliability and efficiency at a price you can afford**

The SP series is a breakthrough for suspended freestanding washer-extractors. The advanced technological features used in this model have made it possible to make a machine that is easy to manufacture and operate at low cost. This is achieved without reducing the quality of the product or the performance. The high speed (G-force) brings down the moisture retention to levels that save significant amounts of energy and time. Labor cost will be reduced and productivity will increase. The SP models generate G-forces almost 4 times greater than conventional standard çHard-To-Mounté machines. The suspension system is soft and absorbs the majority of the vibrations transferred to the floor. The 5 degree lean back of the cylinder will significantly reduce the balance problems and reduce the load on the shaft and bearings increasing the life expectancy. The freestanding models reduce and eliminate variables associated with the installation. In comparison with çHard-To-Mounté machines the installation cost is minimal because of the fact that there is no need for concrete foundations, waiting for curing, grouting or hole drilling. A freestanding machine can be running up in a matter of hours while a çHard-To-Mounté that requires concrete and grouting can take weeks before they are ready to start up. The SP models can be installed in the most unconventional locations including upper floors in high buildings with little or no preparation and cost. They can freely be moved to other places in the laundry should it be necessary to relocate or expand the operation. All these features will make the SP models surprisingly affordable to install and the savings could pay for the machines in short time. The SP models are the ultimate solution to savings in laundries as drying time, operating time, utility consumption and labor expenses can be reduced significantly while increasing the productivity.

# I M A G E



### **Large Door Opening and Safe Door Interlock**



Loading and unloading are fast and easy through the oversized door that opens 180 degrees away from laundry carts. The door is located at a convenient height for laundry carts. The door is constructed of stainless steel and built with an oversize stainless steel hinge for extra strength and durability. The silicone door gasket is designed for long life and seals to the shell every time without leaking. A powerful and safe electro-mechanical door interlocking system is provided for safe and easy operation.

### **Powerful Flexible Control**



The EL 6 control center is easy to use and has the features needed for maximum productivity and lowest cost of operation. The microprocessor controls the temperatures, water levels, speeds and maintenance intervals. A thermal cool down is programmable that will ensure optimal performance for any garments that require special wrinkle control and other special treatments. It can be programmed from the keypad or with a laptop computer. It can also be used with a memory card that significantly simplifies the programming at installation. The EL 6 can be programmed to display in five languages and keep track of operation times, number of cycles and maintenance. It has features for programming any wash activity to meet today and tomorrow's demand for water treatment of textile fiber and garments. It is the most flexible control yet developed for the stand-alone commercial and industrial washers in the industry and has proven track record for reliability.



# High Speed Professional Washer-Extractors

## High Speeds save Energy, Time and Money

A factor that can significantly affect the operation throughput in a laundry is the machine's extraction speed. A machine with a G-force of 350G will save a significant amount of energy and time in the drying process compared to a low speed 80G machine, as more water is extracted from the load during the extraction cycle. In fact the energy and time saving can pay for the cost of the equipment! Your dryers would not work overtime, either. Goods can be taken straight from the washer-extractor to an ironer or finisher without slowing down the productivity. The high speed or G-force is the driving factor. By utilizing the inverter technology it has been possible to achieve this high-speed extraction in freestanding machines. The inverter automatically measures the out of balance electronically and decides if the machine can proceed to high speed generating the high G-force.

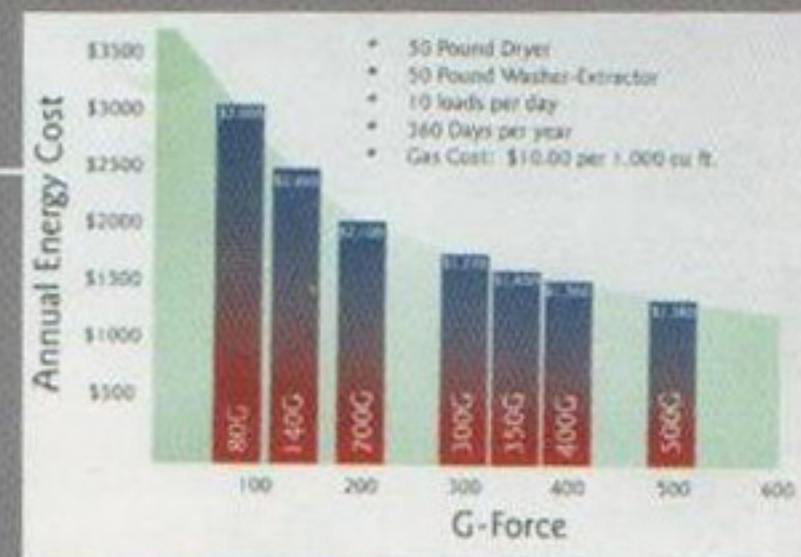

## Supply Dispenser and External Liquid Supply Connection

Machines connected to a central liquid system have a single compartment supply dispenser as standard. A five compartments dispenser is optional for machines using powder chemicals. The dispenser is mounted in the front of the machine at a convenient height for easy reach. The location of the dispenser allows machines to be placed next to each other. The dispenser is flushed automatically. All machines are provided with six supply signals and liquid connections as standard.

## Robust Energy Efficient Drive

The machine is provided with a single totally enclosed standard motor that is controlled electronically by a variable frequency drive. This makes the machine control simple and very flexible. The inverter reduces the peak energy demand, saving energy and lowers the inrush current. It is also a watchdog for the motor, protecting against overload and over voltage. The single motor drive and inverter eliminates clutches, gear reducers, idlers, plus reduces the use of electromechanical components such as contactors and relays. It provides a powerful yet simple drive alternative that is more economical than multi motor drives. The inverter makes it possible to achieve high extract speeds that achieve significant energy and time saving in the drying process.

## Freestanding Construction

A freestanding machine at hardmount pricing plus all the benefits such as reduced installation costs and productivity increase make the SP models superior. No need for expensive foundation or floor modifications. A G-force of 350G means less time in the dryer, saving energy and money. Look inside the SP models and you discover a suspension system that is unsurpassed with heavy springs and industrial shock absorbers. This means lower maintenance costs and super long life.



## Solid Bearing Housing

Rugged cast iron construction is used in our single durable bearing housing. The single bearing housing increases the structural integrity and provides for longer bearing and seal life. The revolutionary CARB torroidal SKF bearing used in the machine is the ultimate long life solution for high-speed washers that the industry has been searching for. The shaft is made of high tensile strength steel that meets the high standards used for load calculation of bearings and shaft. Two double lip seals and face seals protect the bearings. The seals as well as the bearings can be greased manually yielding longer life. The machines have a provision for easy installation of automatic lubricators. Should the seals leak, the main bearings will not be damaged, thanks to an extra large leak off area in the bearing housing. A large leak off area is the answer to long bearing life, as water cannot enter the bearings.

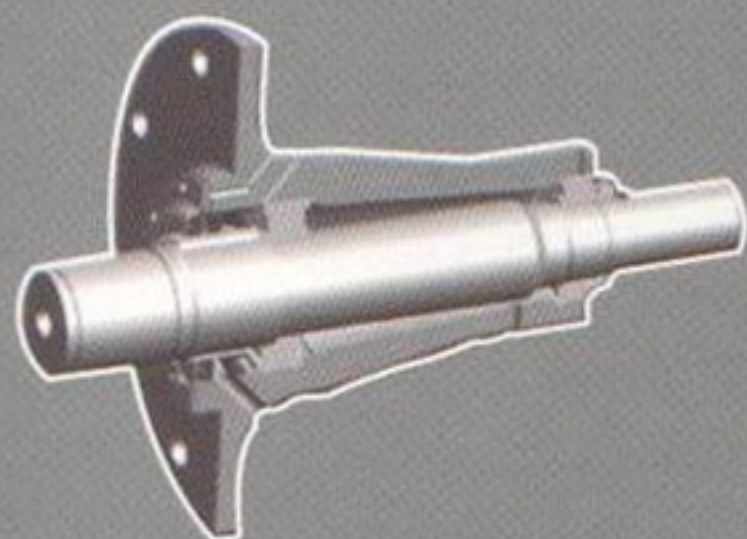



# Specifications

MODEL	Metric	US	SP - 40	SP - 60	SP - 100	SP - 155	SP - 185
Maximum Capacity	Kgs.	Lbs.	18.7 (41)	27.4 (60)	47.8 (105)	71 (156)	84 (186)
<b>Overall Dimension :</b>							
A - Width	mm.	Inch.	925 (36.4)	1003 (39.5)	1204 (47.4)	1335 (52.6)	1479 (58.2)
B - Depth	mm.	Inch.	1093 (43)	1232 (48.5)	1395 (54.9)	1636 (64.4)	1750 (68.9)
C - Height	mm.	Inch.	1466 (57.7)	63.6 (1615)	1805 (71)	1925 (75.8)	1924 (75.7)
<b>Wash Cylinder Information :</b>							
Basket Diameter	mm.	Inch.	680 (26.8)	790 (31.1)	940 (37)	1092 (43.0)	1174 (46.2)
Basket Depth	mm.	Inch.	515 (20.3)	560 (22)	690 (27.2)	757 (29.8)	780 (30.7)
Basket Volume	Cu.m.	Cu.ft.	0.187 (6.6)	0.27 (9.7)	0.48 (16.9)	0.71 (25)	0.84 (29.6)
<b>Motor :</b>							
Size	kW	HP	2.2 (3)	3.7 (5)	5.5 (7.5)	11 (15)	15 (20)
<b>Cylinder Speeds (Programmable) :</b>							
Wash	G	rpm	0.8 (42)	0.8 (42)	0.8 (39)	0.8 (36)	0.8 (35)
Distribution	G	rpm	2 (73)	2 (67)	2 (62)	2.5 (64)	2.5 (62)
Intermediate extraction	G	rpm	150 (829)	150 (583)	150 (535)	79 (360)	95 (380)
High extract 1	G	rpm	200 (725)	200 (673)	200 (618)	140.5 (480)	142 (465)
High extract 2	G	rpm	250 (811)	250 (753)	250 (690)	219.5 (600)	220.5 (580)
High extract 3	G	rpm	350 (960)	350 (890)	350 (817)	320.5 (725)	321 (700)
<b>Door Opening :</b>							
Door Opening Diameter	mm.	Inch.	370 (14.6)	450 (17.7)	508 (20)	635 (25.0)	635 (25.0)
Height to bottom of door	mm.	Inch.	655 (25.8)	740 (29.1)	800 (31.5)	830 (32.7)	870 (34.2)
<b>Drain System :</b>							
Overflow Size	mm.	Inch.	38.1 (1.5)	38.1 (1.5)	38.1 (1.5)	38.1 (1.5)	63.5 (2.5)
Drain Outlet Size	mm.	Inch.	63.5 (2.5)	76.2 (3)	76.2 (3)	76.2 (3.0)	101.6 (4.0)
Number of Drain Outlet	Standard	Optional	1 (2)	1 (2)	1 (2)	2 (2)	1 (2)
<b>Steam Inlet :</b>							
Connection Size	NPT		1/2"	1/2"	1/2"	1"	1 1/4"
<b>Water Inlet :</b>							
Connection Size	NPT		3/4"	3/4"	1"	1 1/4"	1 1/4"
Number of Inlets	Standard	Optional	2 (3)	2 (3)	2 (3)	3 (4)	3 (4)
<b>Chemical Supply System :</b>							
Number of Dry Chemical Compartments	Standard	Optional	1 (5)	1 (5)	1 (5)	1 (5)	1 (5)
Number of Liquid Supply Connections	Standard	Optional	6 (8)	6 (8)	6 (8)	1 (5)	1 (5)
Liquid Supply Connection Size	NPT		1/2"	1/2"	1/2"	1/2"	1/2"
<b>Weight and Shipping Information :</b>							
Net weight	Kgs.	Lbs.	591 (1300)	660 (1540)	1591 (3500)	2075 (4574.5)	1899.5 (4187.6)
Domestic Shipping Weight	Kgs.	Lbs.	610 (1342)	720 (1584)	1635 (3598)	2132 (4700.25)	2039.5 (4496)

Specification and Design subject to change without notice  
Additional options : Consult factory or distributor

## Standard Features :

- All wetted parts are 304 (18/8) stainless steel
- 1 compartment supply dispenser
- 6 external liquid supply connections
- Advanced microprocessor
- 350G extract force
- 5 degree lean back for strength and easy loading
- Built in vacuum breaker
- Variable frequency drive
- Stainless steel cabinet
- Single motor drive
- Cool down
- Robust spring suspension system with industrial shock absorbers
- Water reuse capable

## Optional Features :

- Direct steam heating
- Electrical heating
- 5 compartment dispenser
- Water reuse drain and inlet
- EMI filter for CE
- PC programming kit

